

**PLAN VIEW**  
RIGHT HINGE  
**SELECT**

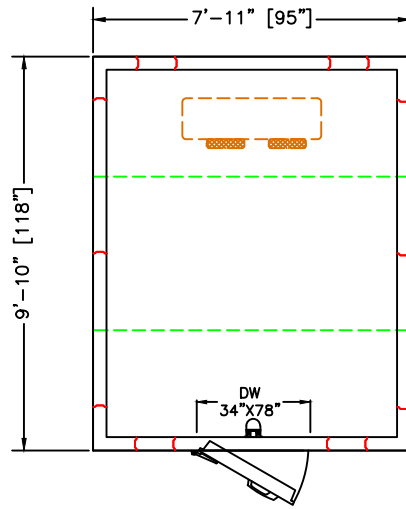

**PLAN VIEW**  
LEFT HINGE  
**SELECT**

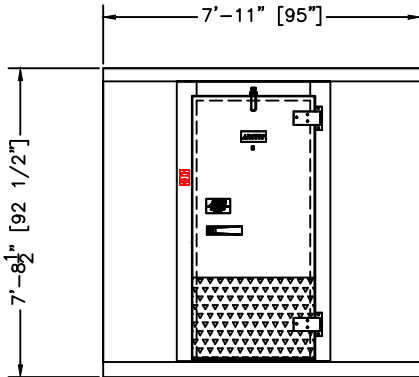

**ELEVATION**  
RIGHT HINGE

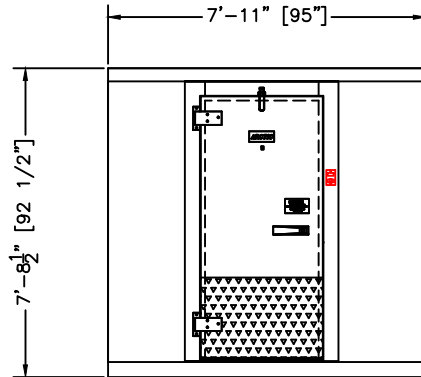

**ELEVATION**  
LEFT HINGE

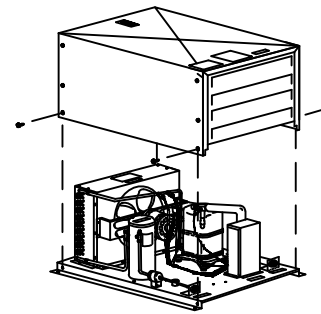

**CONDENSING UNIT**  
**DETAIL**

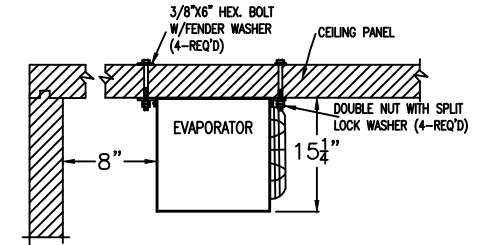

**EVAPORATOR MOUNTING DETAIL**  
**(MOUNTING HARDWARE**  
**BY OTHERS)**

PRODUCT SPECIFICATIONS	
MODEL:	BL810-F-R
WALK-IN SPECIFICATION	
INTERIOR/EXTERIOR FINISH	26 GAUGE MILL EMBOSSED ACRYLUME OR 26 GAUGE STUCCO EMBOSSED GALVANIZED STEEL
ELECTRICAL (VOLTS/Hz/PH)	115/60/1
MAX AMP.	0.8
EVAPORATOR SPECIFICATION	
ELECTRICAL (VOLTS/Hz/PH)	230/60/1
AMPS	10.8
WEIGHT (LBS)	58
CONDENSOR SPECIFICATION	
ELECTRICAL (VOLTS/Hz/PH)	208-230/60/1
AMPS	32.2
WEIGHT (LBS)	219
WALK-IN AND REFRIGERATION FREIGHT	
TOTAL SHIPPING WEIGHT (LBS)	1453
MAXIMUM PALLET SIZE	48" X 96" X 102" HIGH
NUMBERS OF PALLETS	2

MODEL: BL810-F-R

INDOOR-WITH FLOOR

FREEZER -10°F

REMOTE PRE-ASSEMBLED REFRIGERATION

CUSTOMER APPROVAL

DATE: \_\_\_\_\_

SIGNATURE: \_\_\_\_\_

**CONFIDENTIAL**

THE DRAWINGS, TECHNICAL DATA, AND ALL OTHER INFORMATION SET FORTH IN THIS DOCUMENT COMPRISE TRADE SECRETS AND CONFIDENTIAL INFORMATION THAT IS THE EXCLUSIVE PROPERTY OF ARCTIC INDUSTRIES, LLC.

USE OF SUCH INFORMATION IS LIMITED TO THE PURPOSE FOR WHICH IT WAS PROVIDED AND NO RECIPIENT IS PERMITTED TO USE, COPY, OR DISCLOSE SUCH INFORMATION EXCEPT AS EXPRESSLY AUTHORIZED BY ARCTIC INDUSTRIES, LLC.



WALK-IN COOLERS AND FREEZERS  
9731 N.W. 114th WAY  
MIAMI, FL 33178  
PHONE: (305) 883-5581  
www.arcticwalkins.com



Intertek  
CONFORMS TO  
UL 513-01

Intertek  
CONFORMS TO  
NSF 510.7